

10. Low Noise, Jitter Hybrid Ovenized SAW Oscillators

Vectron International Announces Technological Breakthrough in Oscillator Design Introduces Evacuated Miniature Crystal Oscillator (EMXO™)



OCXO's (Oven Controlled Crystal Oscillators) are used when frequency vs. temperature requirements are too stringent to be met by a basic XO (Crystal Oscillator) or TCXO (Temperature Compensated Crystal Oscillator). With an OCXO, the temperature of the crystal and critical circuits is kept constant as the temperature outside the oscillator varies. Controlling the temperature inside the oscillator with an oven maintains this constant temperature. In an OCXO, the changes in the ambient temperature are sensed and then fed back to an oven control that continually maintains a constant optimum temperature inside the oscillator enclosure. An OCXO can improve the crystal's inherent stability by more than 5000 times. The oven control system is not perfect, the open loop gain is not infinite, there are internal temperature gradients inside the oven (oscillator) and, in a conventional oven, the circuitry outside the oven shell is subjected to ambient temperature changes that can "pull" the frequency.

The improved temperature stability performance of a conventional OCXO over an XO or TCXO comes at a steep price. OCXO power consumption, for instance, is greater by a factor of over 200. There is also a size consideration. In an ordinary OCXO, a crystal is enclosed in a metal case, which is then placed inside an oven shell together with temperature sensitive circuitry, and then surrounded by thermal insulation. All this, plus any additional circuitry are then placed in a metal housing making for a bulky package, which becomes very difficult to miniaturize.

To overcome these obstacles, the EX-380 Series EMXO (Evacuated Miniature Oven Controlled Crystal

Oscillator) was specifically developed to achieve OCXO performance while significantly lowering power consumption and reducing package size (See Figure 1).

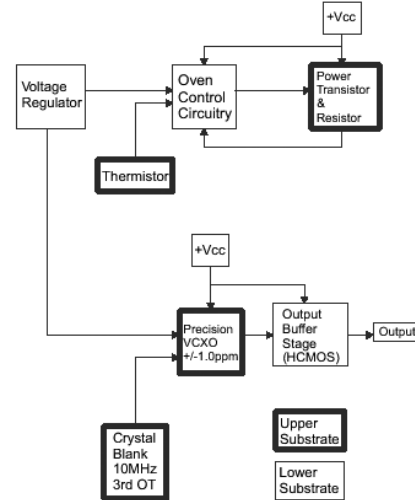

Figure 1. EX-380 Functional Block Diagram

These characteristics go hand in hand since reducing package size makes it easier to improve power consumption. First, the volume of the package was made as small as possible to reduce the volume that the oven needs to heat. Secondly, the most effective insulation needed to be used. In the EX-380 Series, Vectron has done both. The package was designed to single DIP dimensions of 0.82" x 0.52" x 0.3", and the oscillator uses a vacuum as the insulation medium - a dramatic improvement over conventional polyfoam or fiber based insulation material. Another great contributor to Vectron's efforts to reduce size and still provide "oven oscillator" performance was to eliminate the use of large packaged crystals which, up until now, had to be used to achieve good aging. Instead, a way to use an open crystal blank was found and made practical. Vectron has succeeded in resolving outgassing and contamination issues, which could degrade performance. To do this required manufacturing the oscillator with a high internal vacuum level, with low internal outgassing, to provide the needed thermal insulation. A high level of cleanliness was needed to prevent contamination of the open (un-encased) crystal blank and to ensure exceptional long term crystal aging.

The key design feature of this package utilized the concept of integrating the precision crystal in blank form in combination with hybrid microelectronics circuitry. In doing this, obtaining good aging performance was paramount. For this reason, a cold welded pack-

10. Low Noise, Jitter Hybrid Ovenized SAW Oscillators

concept of integrating the precision crystal in blank form in combination with hybrid microelectronics circuitry. In doing this, obtaining good aging performance was paramount. For this reason, a cold welded package was chosen rather than a more traditional resistance welded package. Cold weld sealing provided a true metallurgical bond between ductile metal surfaces without added heat from the sealing process. Under the high tonnage pressure introduced through the indentation of the welding die, a plasticity flow of material takes place on the mating surfaces. The end result is a hermetically sealed enclosure without contamination from weld splashes, dust and vapors. And, most important, cold weld sealed enclosures achieves a high level of vacuum integrity.

Mechanically, the hybrid circuit and crystal assembly is suspended directly over a highly insulating structure to minimize heat energy loss through conduction. In addition, the entire assembly is thermally insulated to the enclosure by vacuum at a pressure level of 10⁻⁶ torr. Based on the steady state thermal conduction calculation, this package design resulted in a thermal resistance of >300 degrees C/watt.

The EMXO manufacturing process is interesting and a process flow diagram is shown below in figure 2.

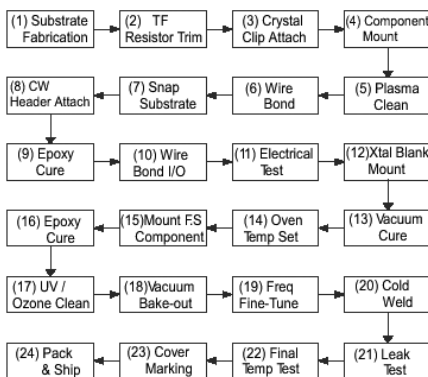
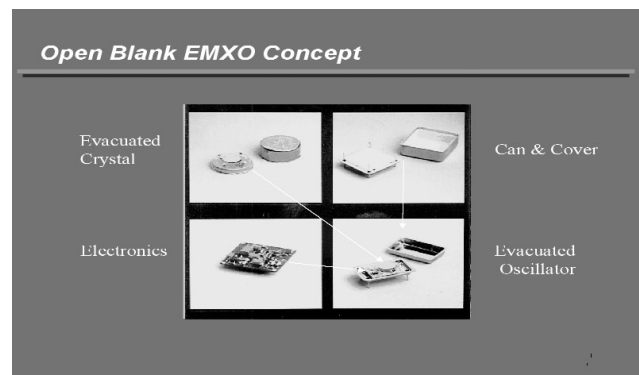

Figure 2. EMXO Process Flow Diagram

Substrates are fabricated with thick film screen printing techniques with each deposition layer subjected to three different process stages - print, dry and fire. Crystal clips are attached to the gold conductor trace on a substrate with high thermal conductivity. All active and passive components are mounted on the substrate using a conductive adhesive and then moved to a convection oven for curing. After the cure process, the

hybrid is cleaned to remove organic and non-organic contaminants. Wires are bonded on the hybrid circuit as interconnects. The hybrid circuits are then attached to the cold-weld package with adhesive. Finally, blank crystals are mounted onto the clips and tuned to the nominal frequency needed, by an evaporation process, to a typical accuracy of 1 ppm. The units are then cold weld sealed. The oven itself is heated by direct thermal conduction applied to a heat conductive substrate. This "Open Blank" EMXO concept is shown and compared to conventional OCXO construction, in Figure 3 below.



In figure 3 above, 1, 2 and 3 reflect conventional OCXO construction while 4 is the EMXO. It shows the major elements of the SDIL EMXO. Only one substrate is used and all the elements are heated. The oscillator is essentially a CMOS gate type with an additional varactor diode and LC trap for overtone select. The resonator is a 3rd Overtone, AT or doubly rotated cut as required by the application, both of which offer superior aging performance when compared to a traditional fundamental resonator.

It is anticipated that the EX-380 Series will find applications where performance in severe mechanical environments is equally important to electrical performance. An additional focus for the EX-380 series, therefore, was to provide robust construction to withstand high shock and vibration and to yield good G-sensitivity performance. For example, when the physical orientation of an oscillator is changed, there is a small frequency change (typically not more than several parts in 10⁻⁹ for a 90-degree rotation) due to change in stress on the crystal blank resulting from the gravitational effect upon the crystal supports. This characteristic is known as "tip-over" and is expressed in 10⁻⁹/g where one g represents one-half of a 180-degree orientation change. To minimize this change

10. Low Noise, Jitter Hybrid Ovenized SAW Oscillators

tional effect upon the crystal supports. This characteristic is known as "tip-over" and is expressed in 10⁻⁹/g where one g represents one-half of a 180-degree orientation change. To minimize this change and also to enhance performance under shock and vibration, the crystal blank is mounted in a symmetrical mounting structure, instead of the more traditional 2 or 3 points. This helps to achieve a high shock and vibration endurance level, low g-sensitivity performance and symmetrical heat transfer. Also, when a crystal oscillator is operating and subjected to vibration, spurious frequencies are generated, offset from the frequency of oscillation by the frequency of vibration. These are commonly referred to as "vibration induced sidebands" and these side bands behave similarly to phase noise. The amplitude of these spurious outputs is related to the amplitude of vibration, the mechanical design of the crystal supports, and the mechanical design of the oscillator assembly, including the crystal mounting. Here also the symmetrical crystal mounting structure helps to reduce unwanted noise.

Both AT and doubly rotated crystals can be used in the EX-380 Series. Even though many types of doubly rotated crystals produce lower amplitude spuri under vibration than the AT, this characteristic is primarily determined by the mechanical design of the crystal and oscillator rather than the specific crystal cut. In many applications, Vectron uses doubly rotated resonators in the oscillator to provide lower close in phase noise, better aging rates and reduced acceleration sensitivity. In less critical applications, less expensive AT cut crystals are used.

Figures 4 through 10 represent the typical actual test data on qualification samples for various characteristics.

Figure 4

Frequency vs Temperature Characteristics EX-380 SERIES @ 10 MHz (Typical)

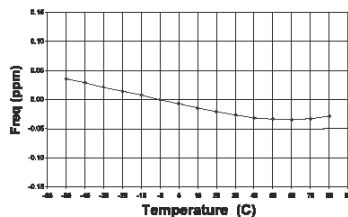

Figure 5

Warm-up (Restabilization) Characteristic at +25°C

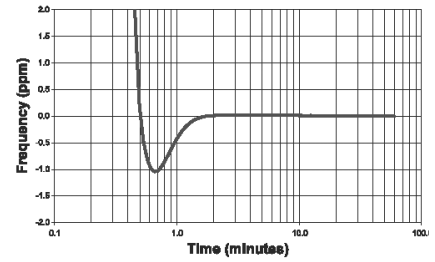

Figure 6

This is a typical phase noise plot for the EX-380 series at 10 MHz. Significant phase noise improvement, both close in and at the noise floor, can be obtained on special order.

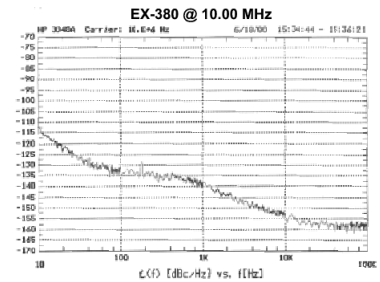

Figure 7

Frequency vs Supply Voltage (Typical)

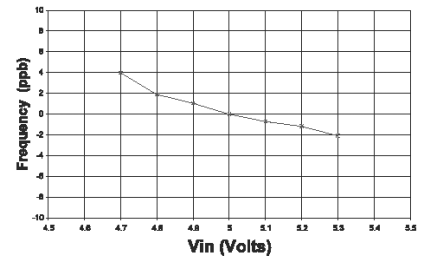

Figure 8

Pullability Characteristic. Frequency Change vs Control Voltage Input

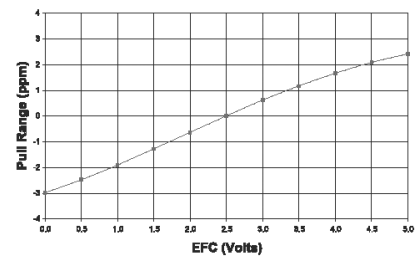
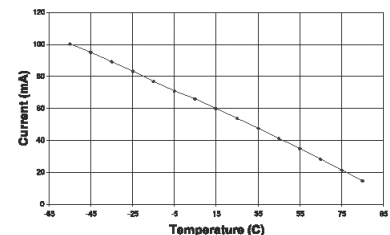

Figure 9

Steady State Current vs Ambient Temperature at 10 MHz (Typical)



10. Low Noise, Jitter Hybrid Ovenized SAW Oscillators

Figure 10

Frequency vs Time.
aging plot @ 10 MHz
(Typical)

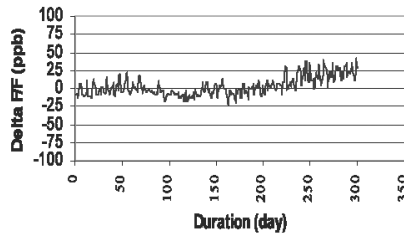

Summary:

The model EX-380, low profile 4 Pin DIP Evacuated Miniature, Oven Controlled Crystal Oscillator (EMXO) is available at selected frequencies from 10 MHz to 20 MHz.

The unit provides exceptionally low aging rates and high temperature stabilities in an extremely small package over a wide range of environmental conditions. The through hole unit measures only 20.8mm x 13.2mm x 7.6mm (0.82" x 0.52" x 0.30"), provides aging rates of $<1 \times 10^{-9}$ /day average, $<1 \times 10^{-7}$ for the first year and $<1 \times 10^{-6}$ for 10 years with temperature stabilities to

$\pm 1 \times 10^{-7}$ over -40°C to $+85^{\circ}\text{C}$. Wider temperature ranges are available from -55°C to $+85^{\circ}\text{C}$. This performance is achieved by the application of new resonator design concepts and technological breakthroughs. The EMXO bridges the gap between current large, high precision OCXO's and smaller TCXO's and becomes the most economical choice where there is a need for spectral purity, short and long term stability, along with small size and dramatically reduced power consumption.

Standard supply voltages for the EX-380 series are 3.3 Vdc and 5 Vdc, with 12 Vdc also available, all with an HCMOS output. A surface mount version of this oscillator is available (EX-385). Sinewave output of +3.0 dBm / 50 ohm is available in the surface mount version.

These EMXO units are ideal for SONET/SDH, DWDM, FDM, ATM, 3G, Telecom Transmission and Switching Equipment, Wireless Communication Equipment and Military Airborne and Mobile systems.