

Specification for monolithic crystal filter: **MQF 73.4 - 2500/02**

1. General

1.1. Package:

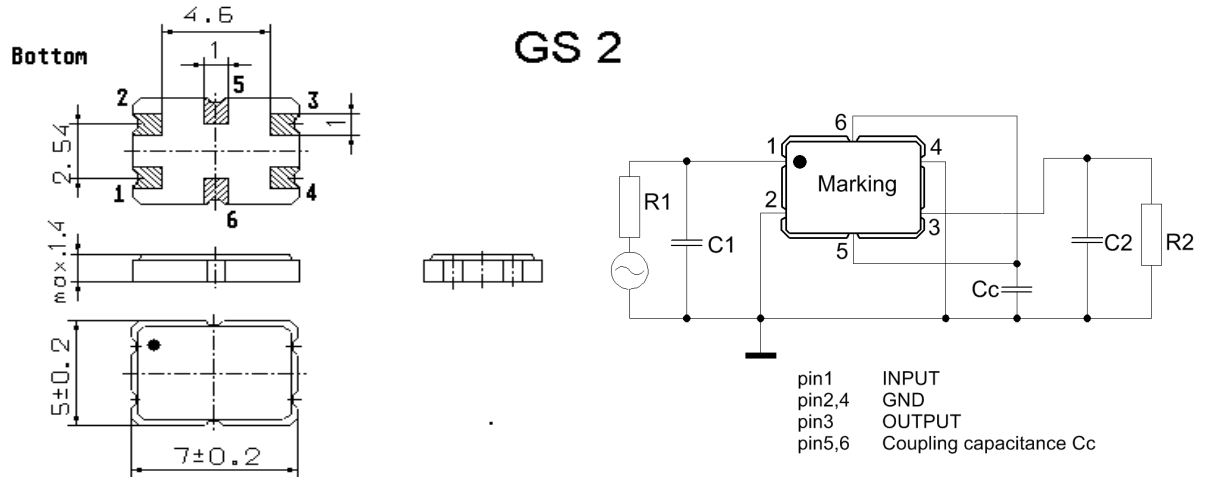

- |                                   |                  |
|-----------------------------------|------------------|
| 1.2. Type name:                   | MQF 73.4-2500/02 |
| 1.3. Number of poles:             | 4                |
| 1.4. Operating temperature range: | -30°C to +85°C   |
| 1.5. Storage temperature range:   | -40°C to +90°C   |

temperature (°C)

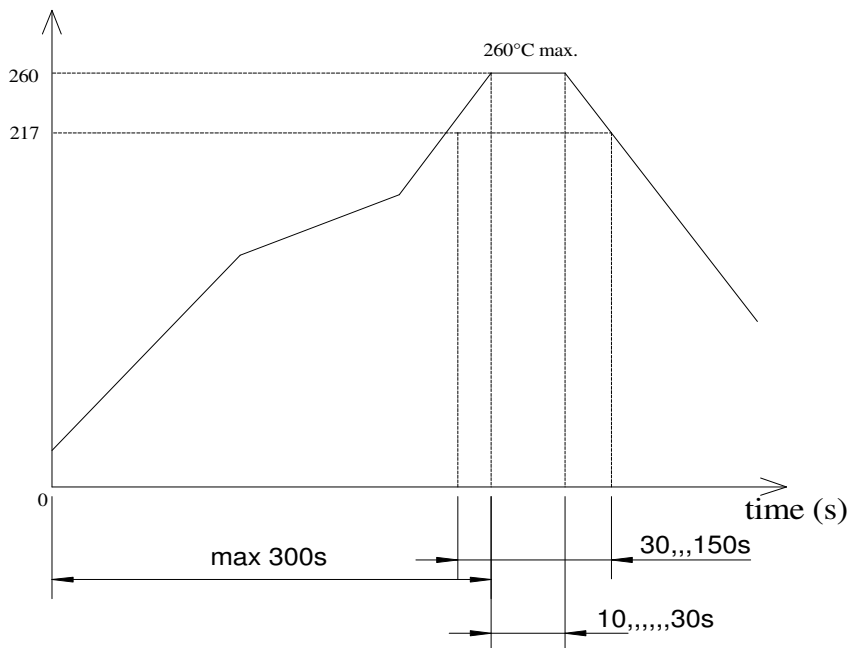

Reflow soldering: three times max.

## 2. Electric values

- 2.1. Nominal centre frequency  $f_0$ : 73.4 MHz  
2.1.1 Centre frequency  $f_c$  at +25°C 73.4 MHz  $\pm$  1.5 kHz
- 2.2. **Pass band**
- 2.2.1. Bandwidth between 3 dB - frequencies:  $> f_c \pm 12.5$  kHz  
2.2.2. Ripple in pass band:  $< 1.0$  dB peak to peak  
2.2.3. Insertion loss:  $< 6.0$  dB  
( measured on smallest attenuation in pass band )  
2.2.4. Differential group delay at  $f_c \pm 9$  kHz  $< 16$   $\mu$ s
- 2.3. **Stop band**
- 2.3.1.  $f_c \pm 25$  kHz  $> 15$  dB  
2.3.2.  $f_c \pm 50$  kHz  $> 40$  dB  
2.3.3. Alternate Attenuation at  $f_c \pm 1.0$  MHz  $> 70$  dB (except spurious)
- 2.4. Terminating impedance R//C ( input and output ): 800  $\Omega$  // 1.5 pF  
2.4.1. Coupling capacitance Cc: 4.0 pF
- 2.5. Maximum input power level  
working: -10 dBm  
non-damaged: 0 dBm
- 2.6. Out band Intermodulation ( IP3  $> +20$  dBm )  
- test tones:  $f_0 \pm 25$  kHz /  $f_0 \pm 50$  kHz  
- Input power level: -20 dBm  
- 3rd order intermodulation products at  $f_0$ :  $> 80$  dB ( down from either of the -20 dBm test tones )
3. Marking on the case: • M73425  
VI yyww
4. Environment conditions: Corresponding to Vectron CF001
5. Filters are Pb-free and 2002 /95 / EC RoHS compliant

## 6. Packing

maximum 1000 pcs. / reel

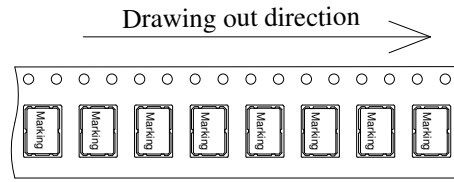

Tape dimension ( mm )

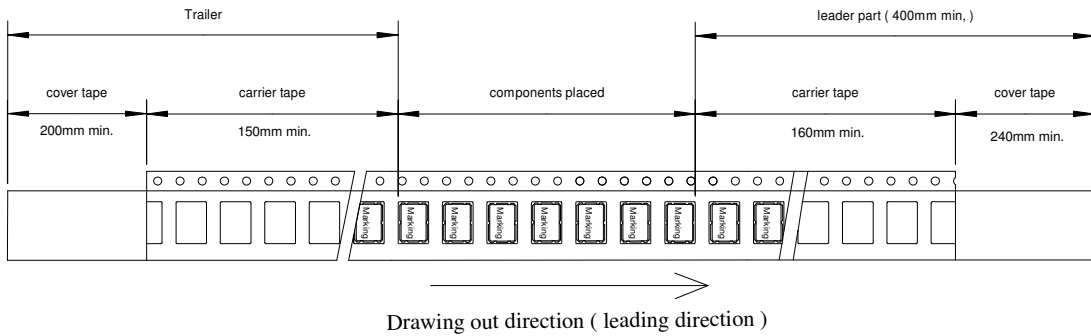

Tape ( all dimensions in mm )

- W:  $16.0 \pm 0.1$
- Po:  $4.0 \pm 0.1$
- P1:  $8.0 \pm 0.1$
- P2:  $2.0 \pm 0.1$
- Do:  $1.5 +0.1 / -0$
- D1:  $1.6 +0.1 / -0$
- E:  $1.75 \pm 0.1$
- F:  $7.5 \pm 0.1$
- Ko:  $1.7 \pm 0.1$
- Ao:  $5.6 \pm 0.1$
- Bo:  $7.6 \pm 0.1$
- t:  $0.3 \pm 0.05$

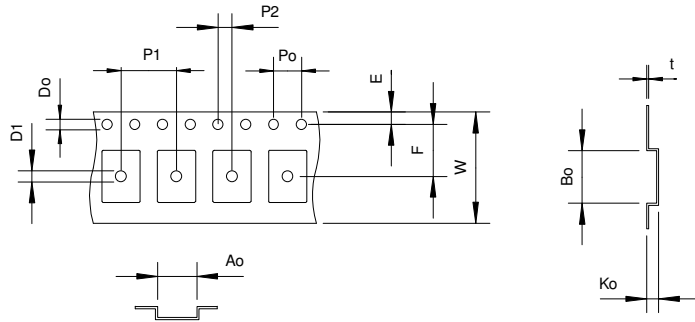

Reel ( all dimension in mm )

- A:  $\varnothing 178 \pm 2$
- C:  $\varnothing 13 \pm 0.5$
- N:  $\varnothing 60 \pm 1$
- W1:  $17.5 \pm 1.5$
- W2:  $21.5 \pm 1.5$

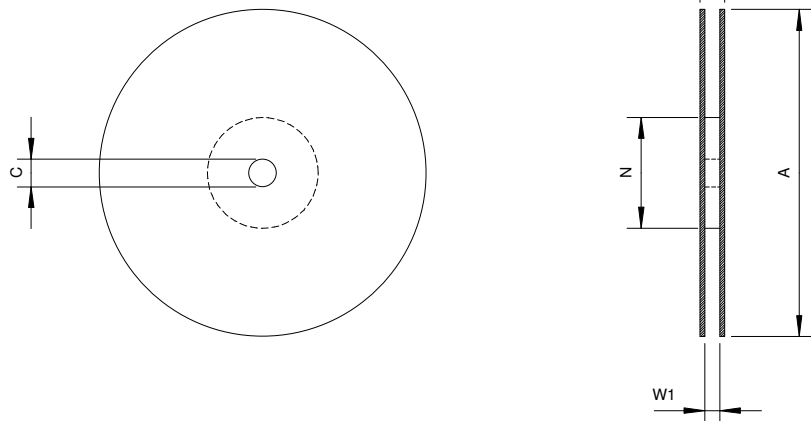

Edited by: \_\_\_\_\_ date: \_\_\_\_\_ name: \_\_\_\_\_