

VI TELEFILTER

Filter specification

TFS 70H13A

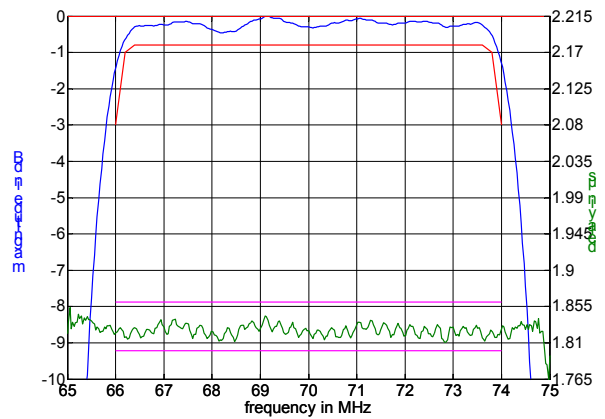
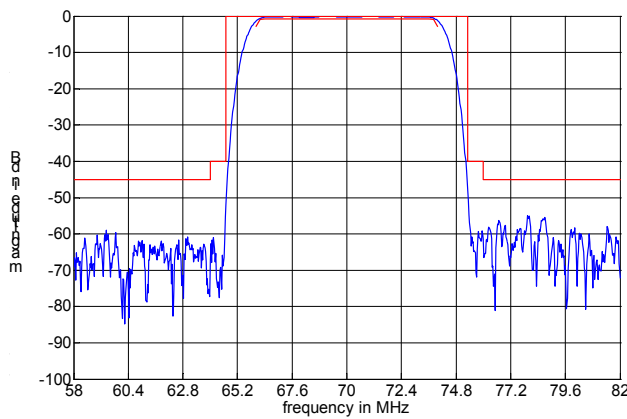

Data		typ. value		tolerance / limit	
Insertion loss (reference level)		a_e	22,7 dB	max.	24 dB
Centre frequency		f_c	70,0 MHz	70,0 ± 0,1 MHz	
Passband		$f_c \pm 4,0$ MHz			
Bandwidth		BW			
1 dB		7,83 MHz	min.	7,6 MHz	
3 dB		8,39 MHz	min.	8,0 MHz	
40 dB		10,62 MHz	max.	10,6 MHz	
Relative attenuation		a_{rel}			
f_c		$f_c \pm 3,6$ MHz	0,45 dB	max.	0,8 dB
$f_c \pm 3,6$ MHz		$f_c \pm 3,8$ MHz	0,6 dB	max.	1 dB
$f_c \pm 3,8$ MHz		$f_c \pm 4,0$ MHz	1,5 dB	max.	3 dB
$f_c \pm 5,3$ MHz		$f_c \pm 6,0$ MHz	45 dB	min.	40 dB
$f_c \pm 6,0$ MHz		$f_c \pm 15,0$ MHz	50 dB	min.	45 dB
$f_c \pm 15,0$ MHz		$f_c \pm 50,0$ MHz	60 dB	min.	50 dB
Group delay		mean value in PB	1,83 μ s	max.	2,5 μ s
				min.	1,5 μ s
Group delay ripple within PB			40 ns	max.	60 ns
Deviation from linear phase within PB			2,4 °	max.	4 °
Triple transit response suppression			54 dB		-
Crosstalk attenuation compared to main signal			60 dB		-
Operating temperature range		OTR	-	- 40 °C ... + 85 °C	
Storage temperature range			-	- 55 °C ... + 85 °C	
Temperature coefficient of frequency		TC_f *	- 87 ppm/K		-

*) $\Delta f(\text{Hz}) = TC_f(\text{ppm/K}) \times (T - T_0) \times f_{T0}(\text{MHz})$

Generated:

Checked / Approved:

Filter characteristic

Tele Filter GmbH
 Potsdamer Straße 18
 D 14 513 TELTOW / Germany
 Tel: (+49) 3328 4784-0 / Fax: (+49) 3328 4784-30
 E-Mail: tft@telefilter.com

VI TELEFILTER reserves the right to make changes to the product(s) and/or information contained herein without notice. No liability is assumed as a result of their use or application. No rights under any patent accompany the sale of any such product(s) or information.

Construction and pin connection

(All dimensions in mm)

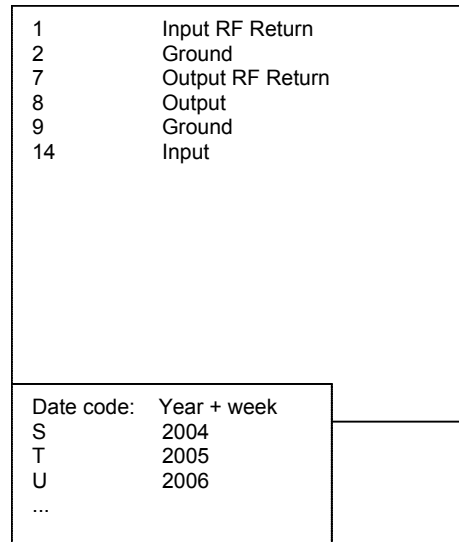
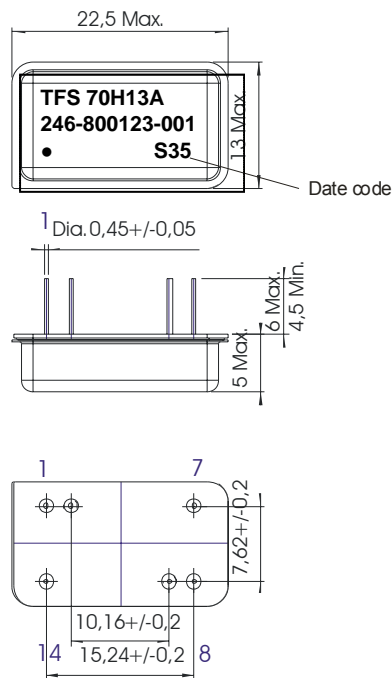

50 Ohm Test circuit

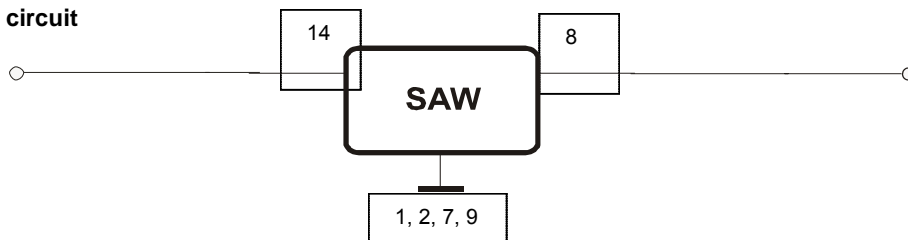

Stability characteristics :

Tele Filter GmbH
 Potsdamer Straße 18
 D 14 513 TELTOW / Germany
 Tel: (+49) 3328 4784-0 / Fax: (+49) 3328 4784-30
 E-Mail: tft@telefilter.com

VI TELEFILTER reserves the right to make changes to the product(s) and/or information contained herein without notice. No liability is assumed as a result of their use or application. No rights under any patent accompany the sale of any such product(s) or information.

After the following tests the filter shall meet the whole specification:

1. Shock: 30g, 11 ms, sawtooth, 3 shocks each plane;
MIL-STD-202, Method 213 test condition K
2. Vibration: 10 Hz to 2000 Hz, 15g, 20min per cycle, 12 cycles per plan, 3 plans;
MIL-STD 202, Method 204, test condition B
3. Thermal shock: -40°C to 85°C, 5 cycles
MIL-STD 202, Method 107, test condition A

Air reflow temperature conditions :

1st and 2nd air reflow profile

Name:	pre-heating periods	main-heating periods	peak temperature
Temperature:	150 °C - 170 °C	over 200 °C	255 °C ± 5 °C
Time:	60 sec. - 90 sec.	20 sec. - 25 sec.	

Air reflow profile

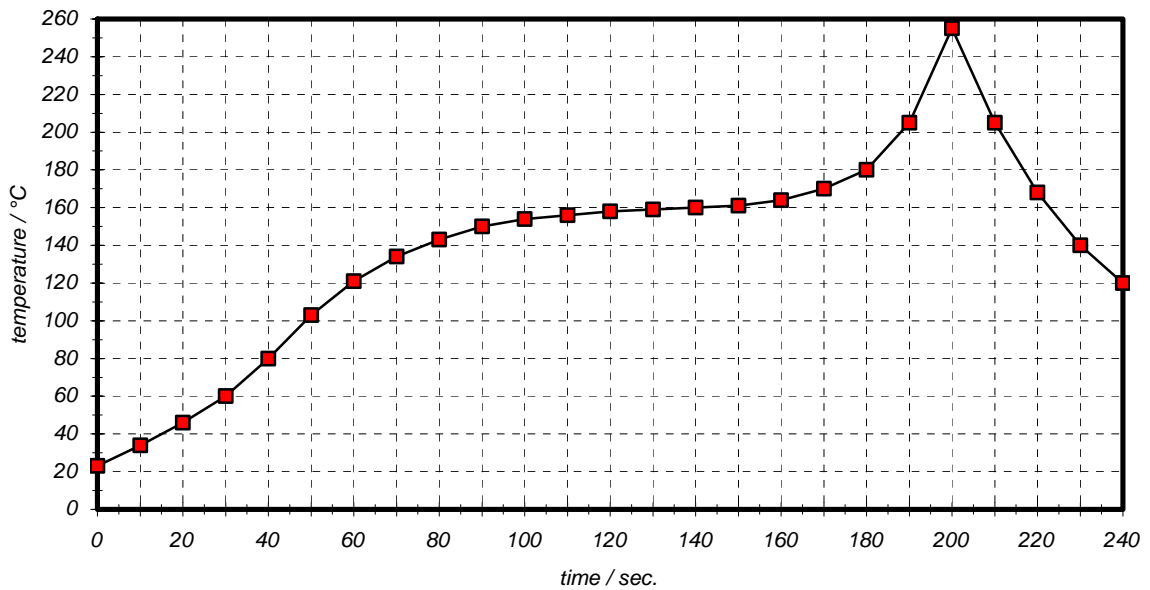

Table for temperature vs. time during the air reflow process

Tolerance of temperatures: ± 5 °C

time / sec.	temperature / °C	time / sec.	temperature / °C
0	23	140	160
10	34	150	161
20	46	160	164
30	60	170	170
40	80	180	180
50	103	190	205
60	121	195	230
70	134	200	255
80	143	205	230
90	150	210	205
100	154	215	180
110	156	220	165
120	158	230	140
130	159	240	120

Tele Filter GmbH
 Potsdamer Straße 18
 D 14 513 TELTOW / Germany
 Tel: (+49) 3328 4784-0 / Fax: (+49) 3328 4784-30
 E-Mail: tft@telefilter.com

VI TELEFILTER reserves the right to make changes to the product(s) and/or information contained herein without notice. No liability is assumed as a result of their use or application. No rights under any patent accompany the sale of any such product(s) or information.

VI TELEFILTER**Filter specification****TFS 70H13A****5/5**

History

Version	Reason of changes	Name	Date
1.0	filter specification created	Pfeiffer	17.06.2004
1.1	operating and storage temperature range extended	Pfeiffer	26.08.2004

Tele Filter GmbH
Potsdamer Straße 18
D 14 513 TELTOW / Germany
Tel: (+49) 3328 4784-0 / Fax: (+49) 3328 4784-30
E-Mail: tft@telefilter.com

VI TELEFILTER reserves the right to make changes to the product(s) and/or information contained herein without notice. No liability is assumed as a result of their use or application. No rights under any patent accompany the sale of any such product(s) or information.